

# active™

S T O R A G E

## mRAID16 Quickstart Guide

# Installation Process

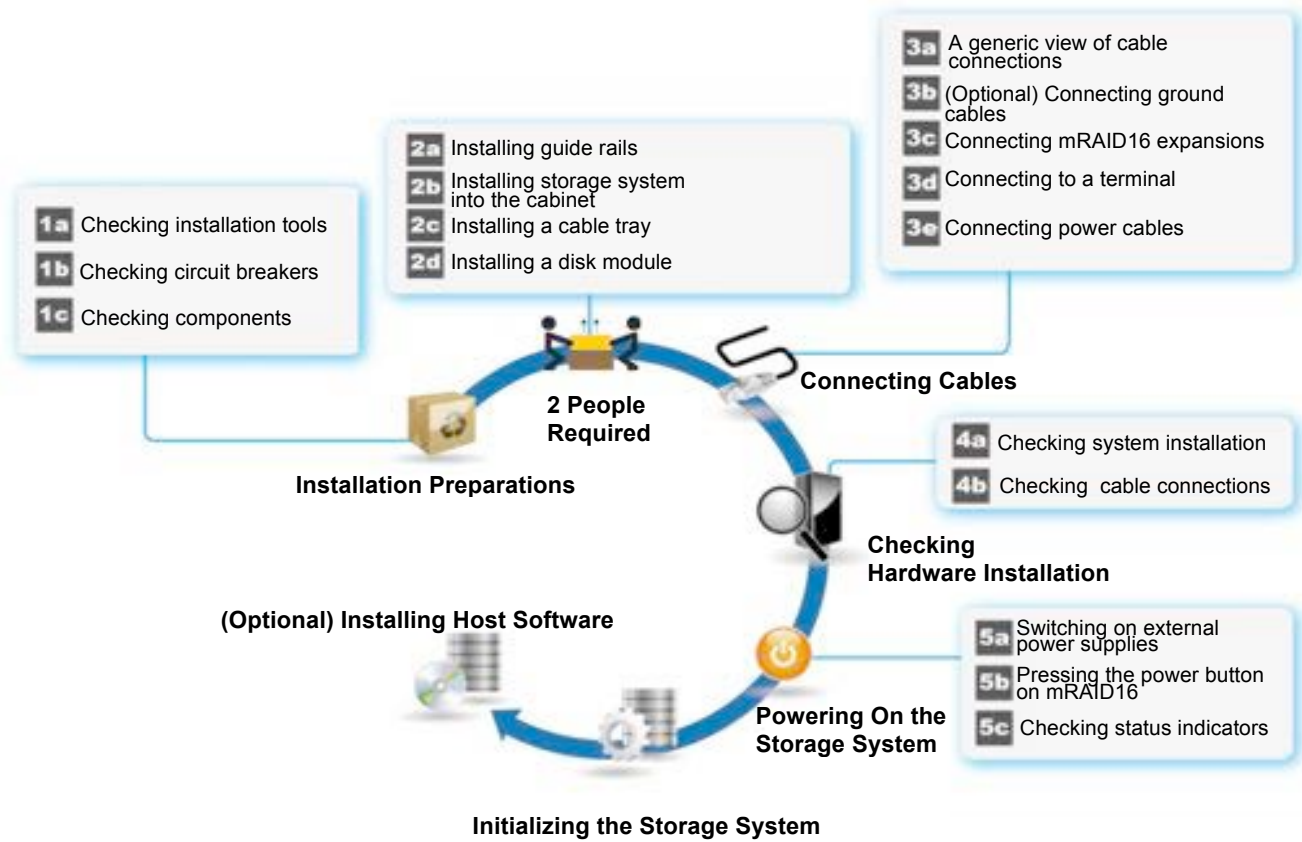

## 2a Installing guide rails

### NOTE

- The adjustable guide rails are 600 mm (23.62 in.) to 900 mm (35.43 in.) long.
- The adjustable guide rails are preconfigured with positioning pins applicable to square holes only. For round holes, replace the positioning pins.
- Two paired adjustable guide rails must be positioned exactly parallel to one another.

Attaching adjustable guide rails for mRAID16

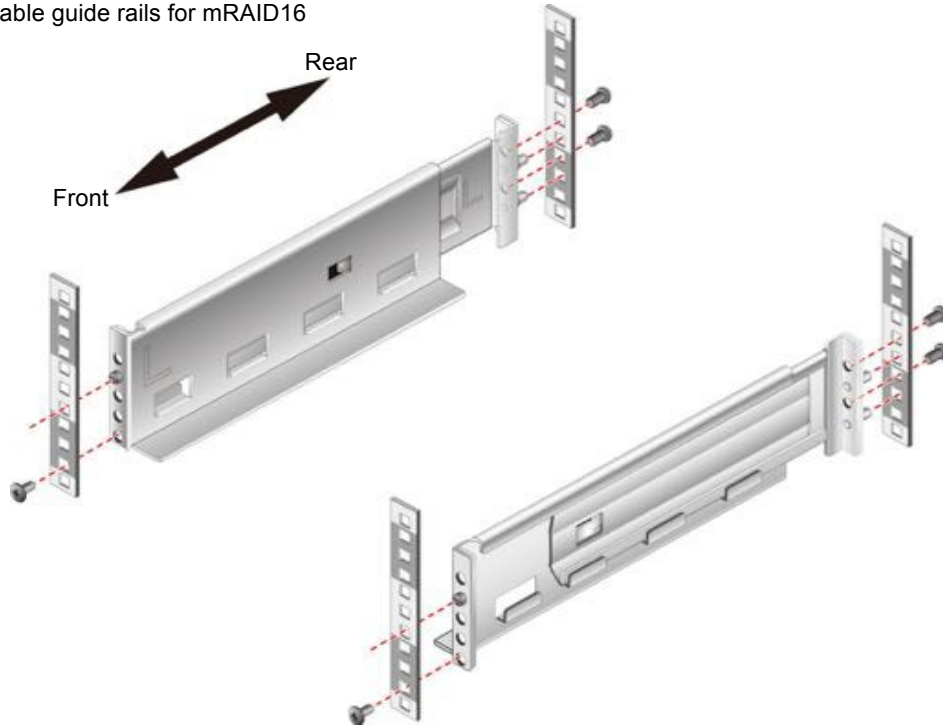

Attaching adjustable guide rails for mRAID16 Expansion

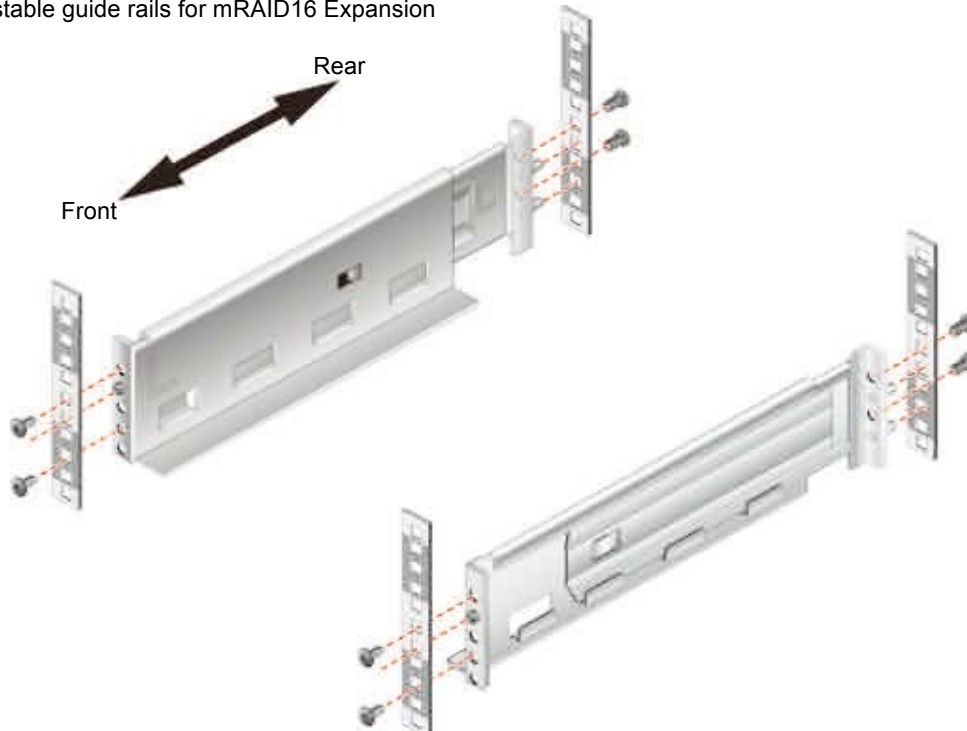

# Installing bearing guide rails for mVault75

(1) Pull out the inner rail of the ball bearing guide rails.

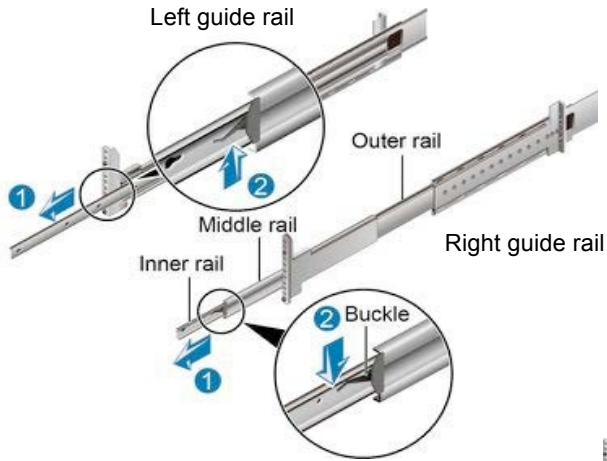

(2) Remove a rail support.

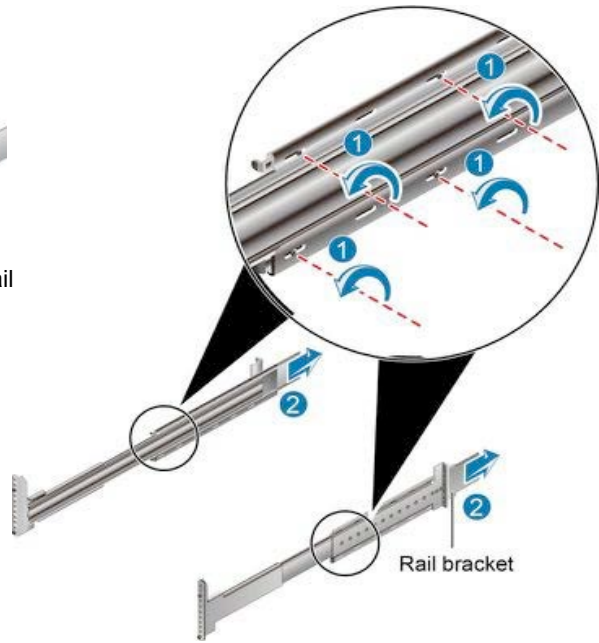

(3) Loosen the screws and adjust the length of the ball bearing guide rail to be the same as the cabinet depth.

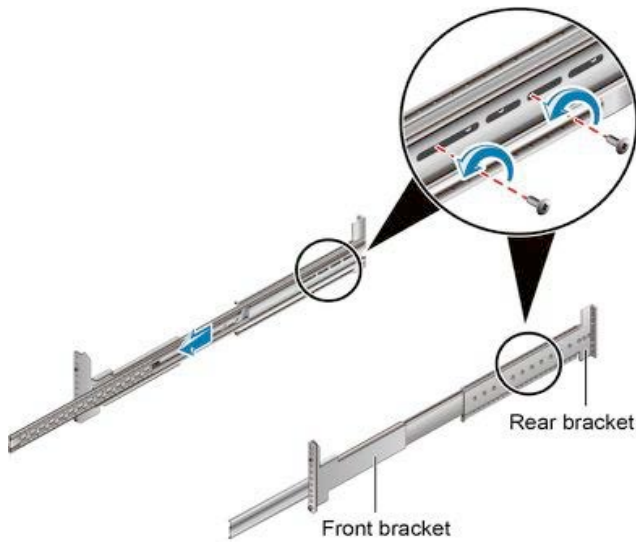

(4) Install the ball bearing guide rails.

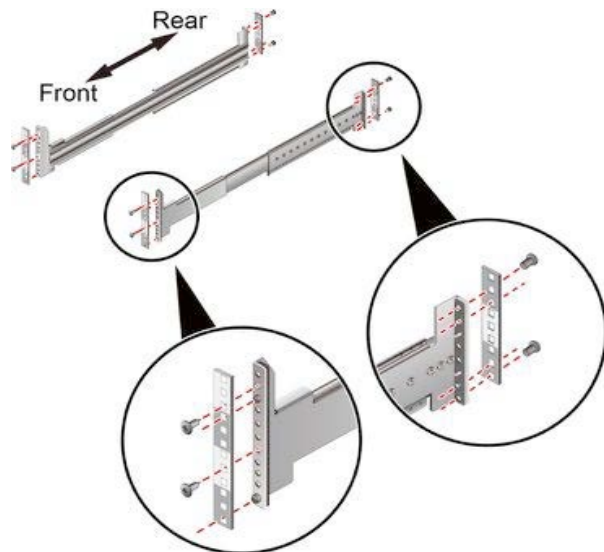

(5) Fasten screws.

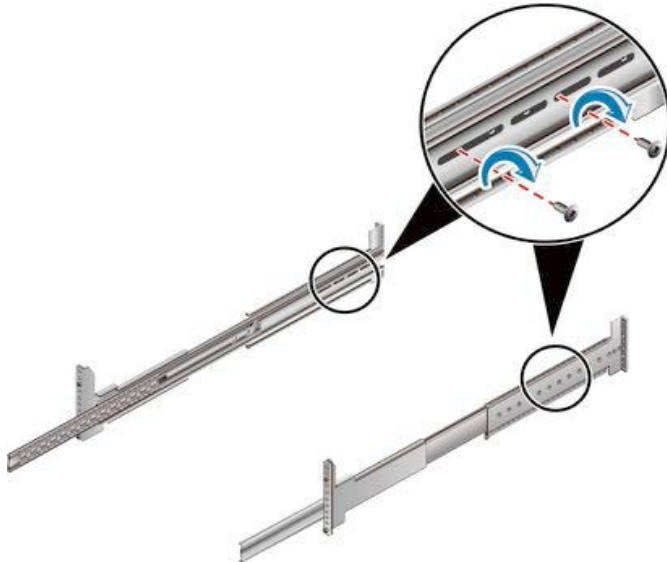

(6) Install a ball bearing guide rail bracket.

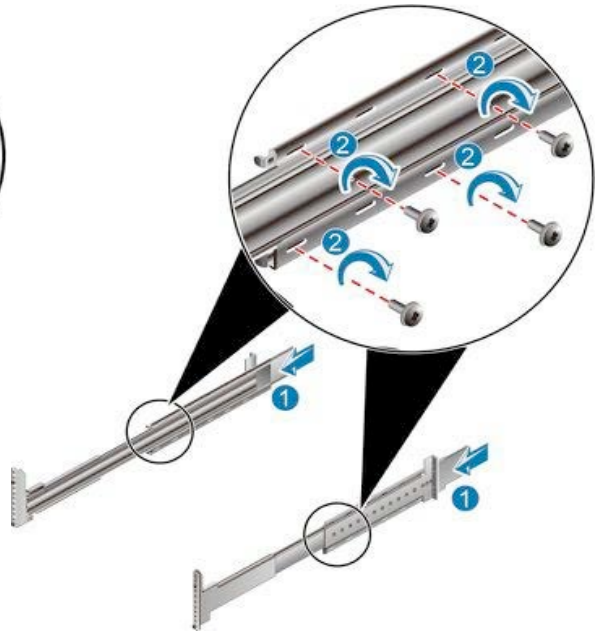

(7) Check the installation of the ball bearing guide rails.

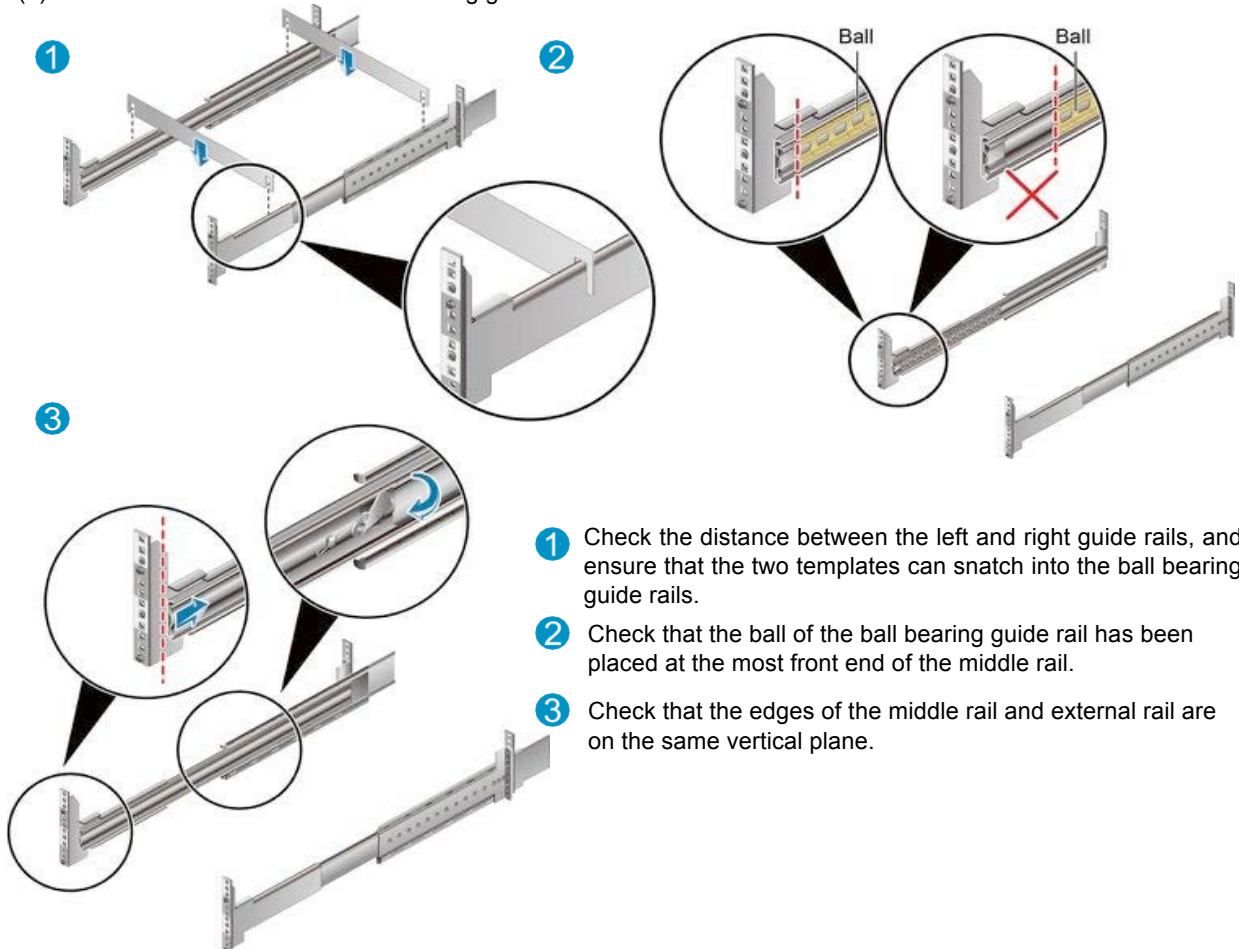

- 1 Check the distance between the left and right guide rails, and ensure that the two templates can snatch into the ball bearing guide rails.
- 2 Check that the ball of the ball bearing guide rail has been placed at the most front end of the middle rail.
- 3 Check that the edges of the middle rail and external rail are on the same vertical plane.

## 2b Installing storage systems into the cabinet

### NOTICE

- Do not stack components. Install them on guide rails.
- If you remove controllers and disks to facilitate a move, record the location of each component and its slot in advance to help when inserting each component back to its correct slot.
- If the controller is inserted into a different location, a system power-on failure may occur.

### Installing mRAID16 and mRAID16 Expansion



### NOTE

Install mRAID16 Expansion on the guide rails using the same method as installing the mRAID16.

### Installing mVault75

(1) Install the inner rail.



(2) Mount the mVault75.

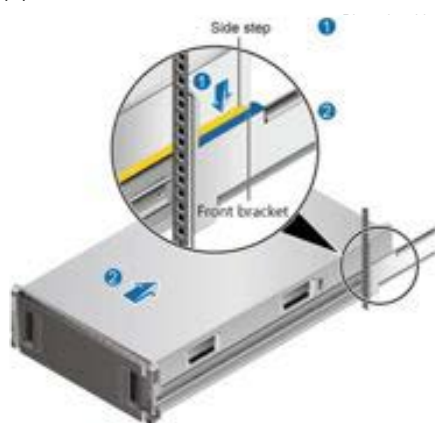

(3) Install the middle rail.



(4)



### NOTE

When mounting the mVault75, place the side step in the rear of the mVault75 on the front bracket of the ball bearing guide rails, and slide the mVault75 in the cabinet along the ball bearing guide rails (no manual alignment is required because the inner rail automatically connects to the middle rail).

## 2c Installing a cable tray

(1) Insert the cable tray into the ball bearing guide rails and the mVault75.

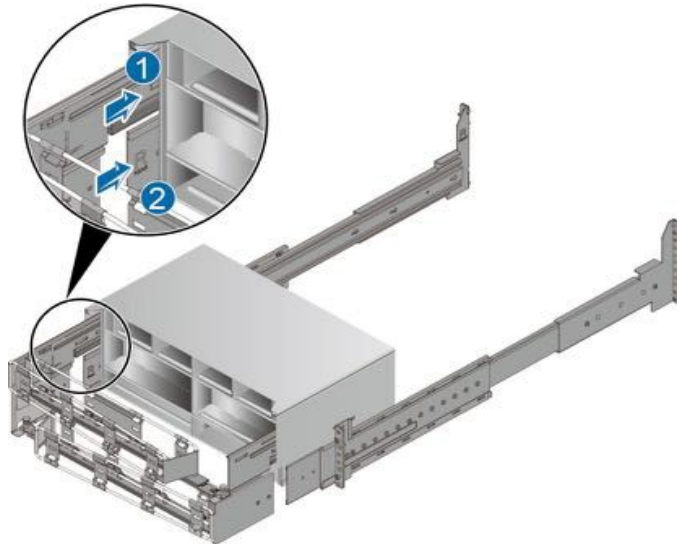

(2) Use a Phillips screwdriver to fasten M6 screws and secure the cable tray.

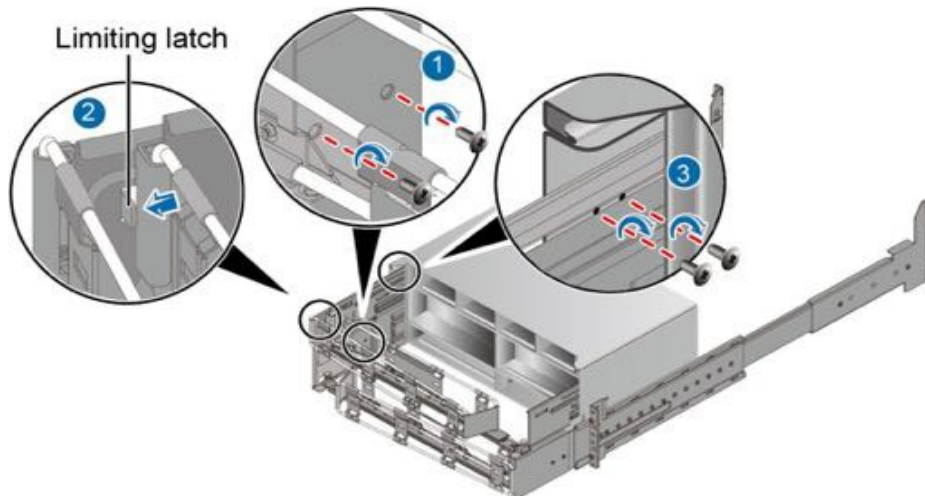

(3) Install the spring pins to cable trays to secure the cable tray.

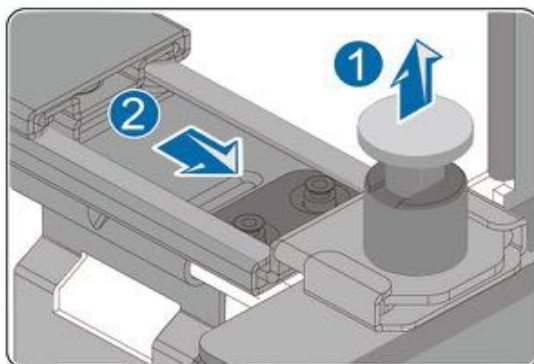

## 2d Installing a disk module

Figure (1)

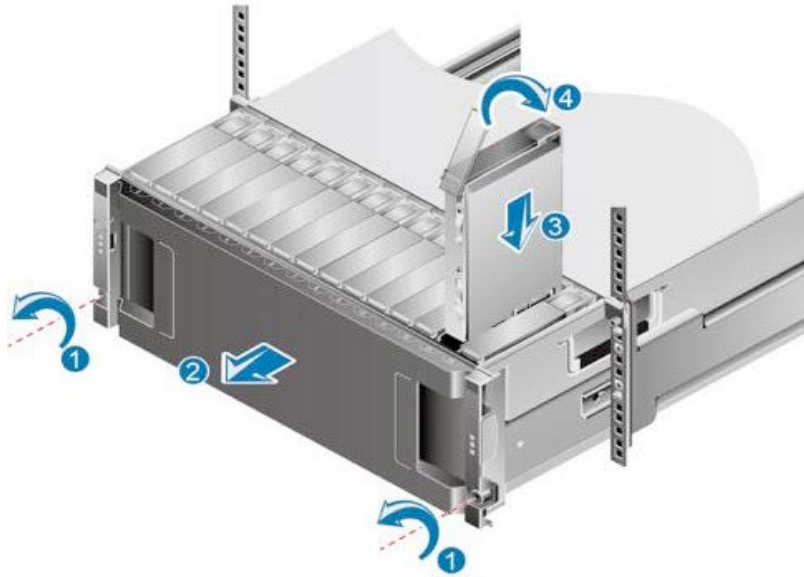

Figure (2)



### NOTE

When installing the disk drive module, refer to step 3 and step 4 in figure (1).



### 3 Connecting Cables

#### 3a A generic view of cable connections on the mRAID16

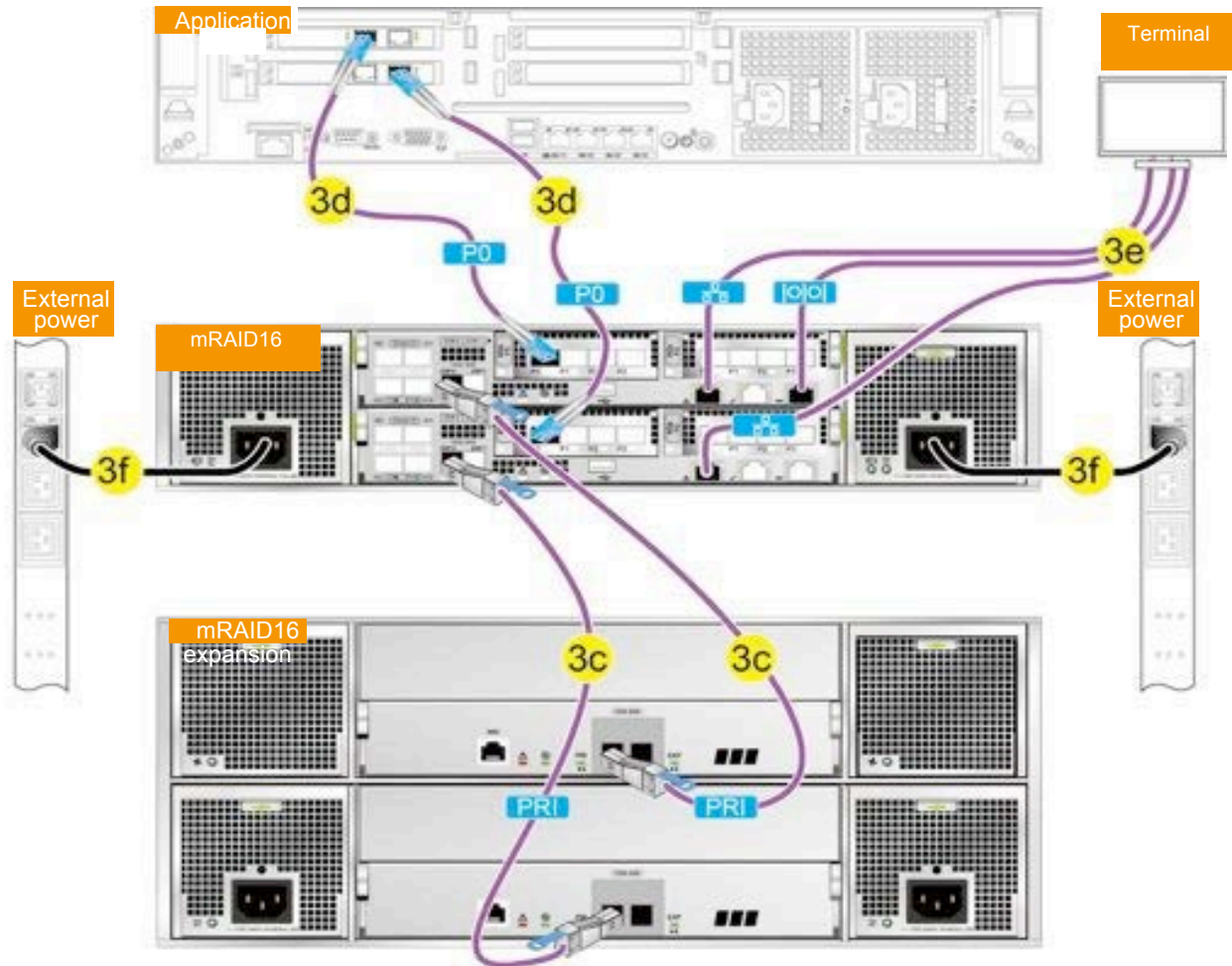

#### 3b (Optional) Connecting ground cables

Connecting ground cables for mVault75.



### 3c Connecting expansions

#### NOTE

- All the EXP ports on the mRAID16 can connect only to the PRI ports. An incorrect connection will cause a service interruption.
- For mEAI16 with two or more mRAID16 Expansions, set up multiple loops based on the number of expansion ports on the mRAID16, and evenly allocate those mRAID Expansions to the loops.
- Connect mRAID16 Expansions in one loop over two separate links for optimal network reliability.

Connecting mRAID16 Expansions

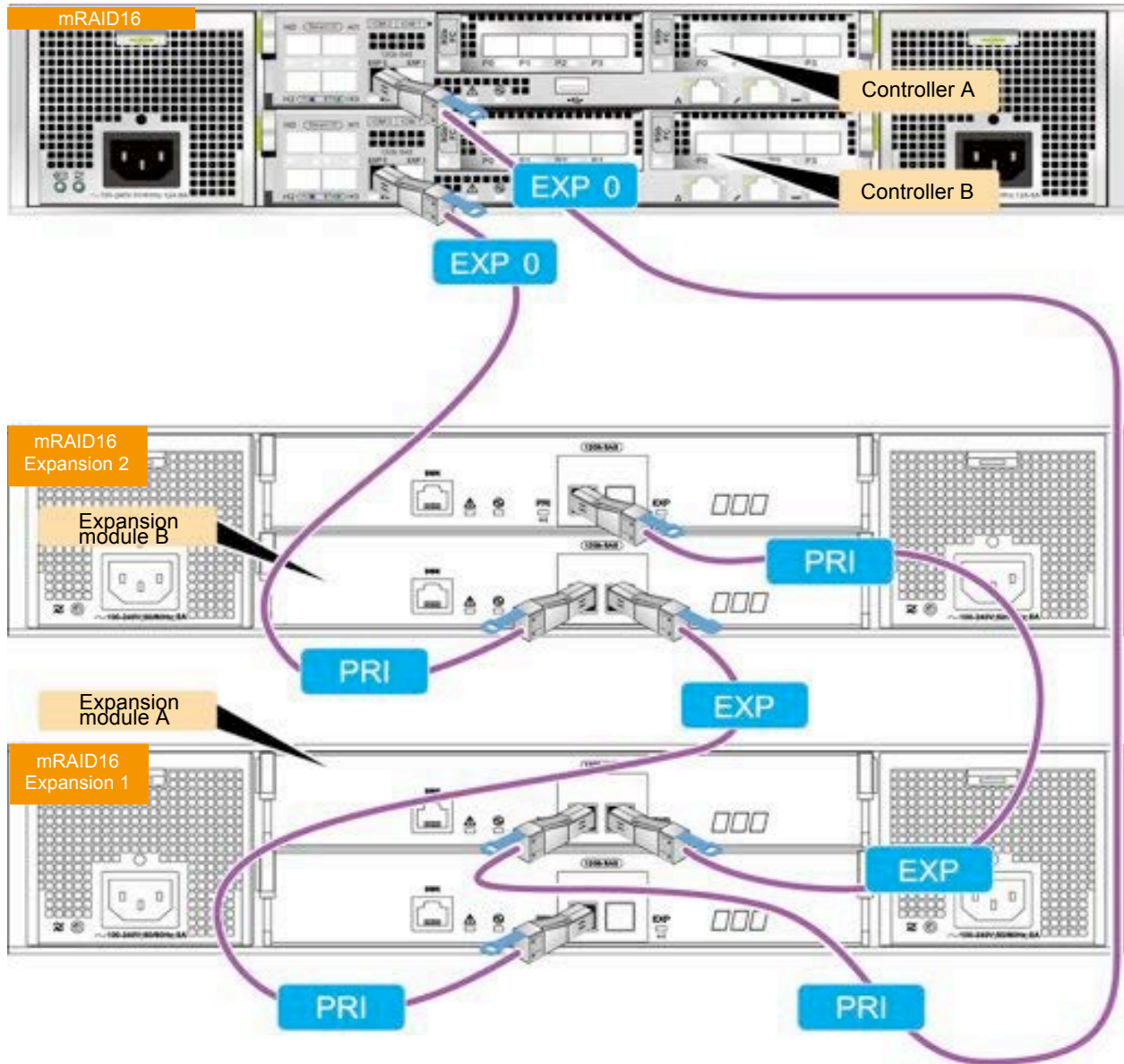

## Connecting mVault75

### NOTE

- Connect two mVault75s using mini SAS HD electrical cables. The cables must be naturally bent and a minimum of 4" clearance must be reserved in front of each mVault75 for winding cables.
- mRAID16 Expansion and mVault75 cannot be connected to one expansion loop.
- Each expansion loop of mVault75 must be connected to two adjacent ports (excluding ports P1 and P2) of the 12 Gbit/s SAS interface module on a mRAID16, for example, ports P0 and P1 or ports P2 and P3.

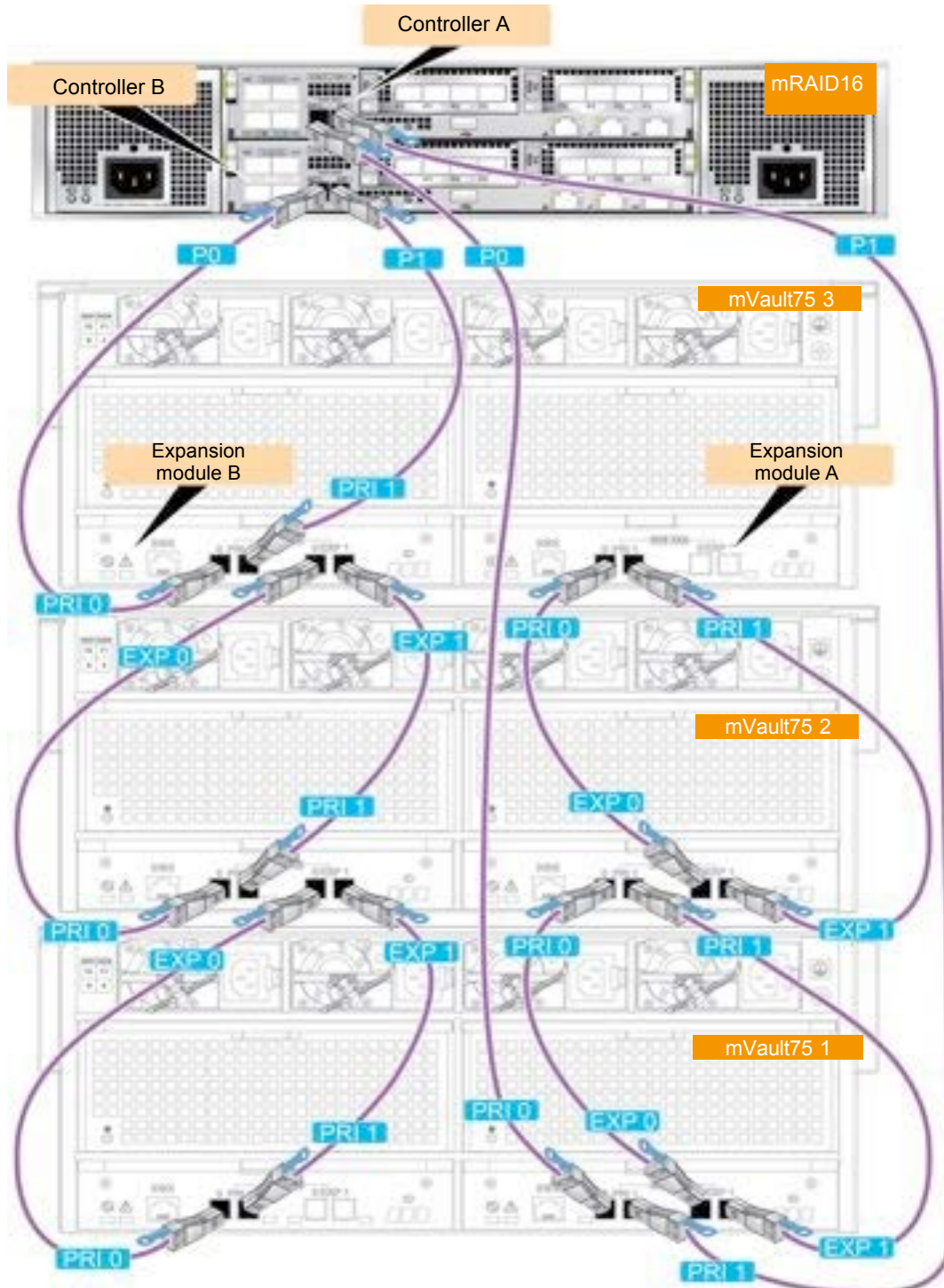

### 3d Connecting to a terminal



#### NOTE

- After connecting a serial port on the storage system to the terminal, you can then manage and maintain the storage system.
- During initial configuration, set an IP address for the management network port through the serial port.

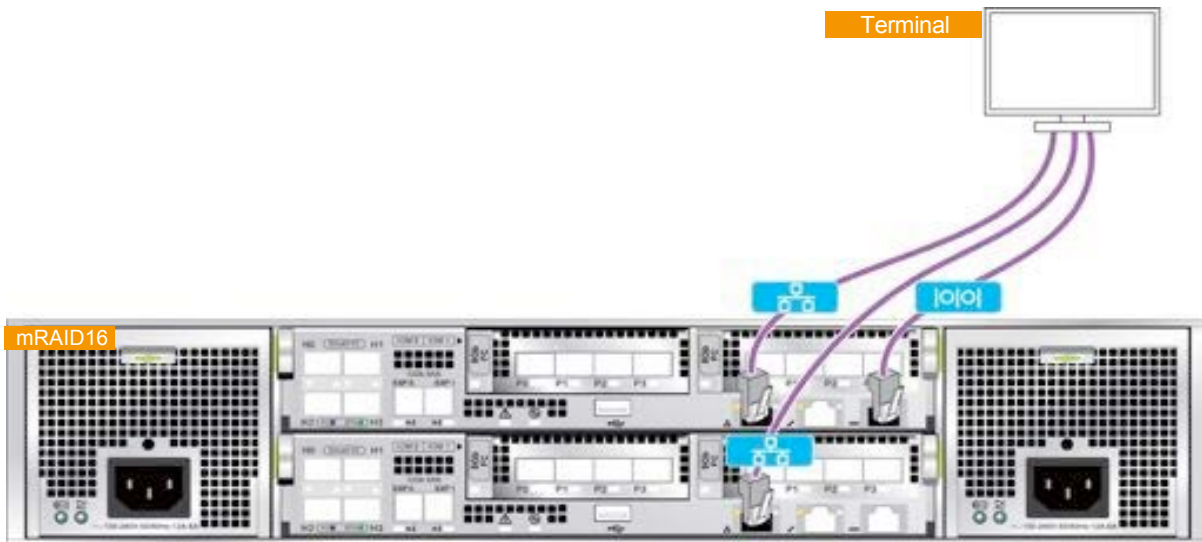

### 3e Connecting power cables



#### NOTICE

To ensure a high availability of the mRAID16 and to avoid unexpected power failure, connect the mRAID16 to two routes of power supplies.

#### Scenario 1 Connecting an AC power cable

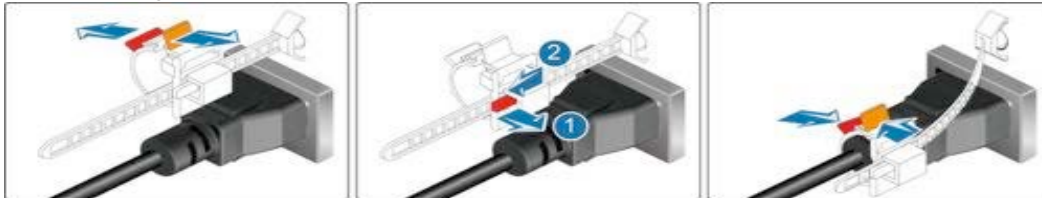

Complete view of the AC power cables

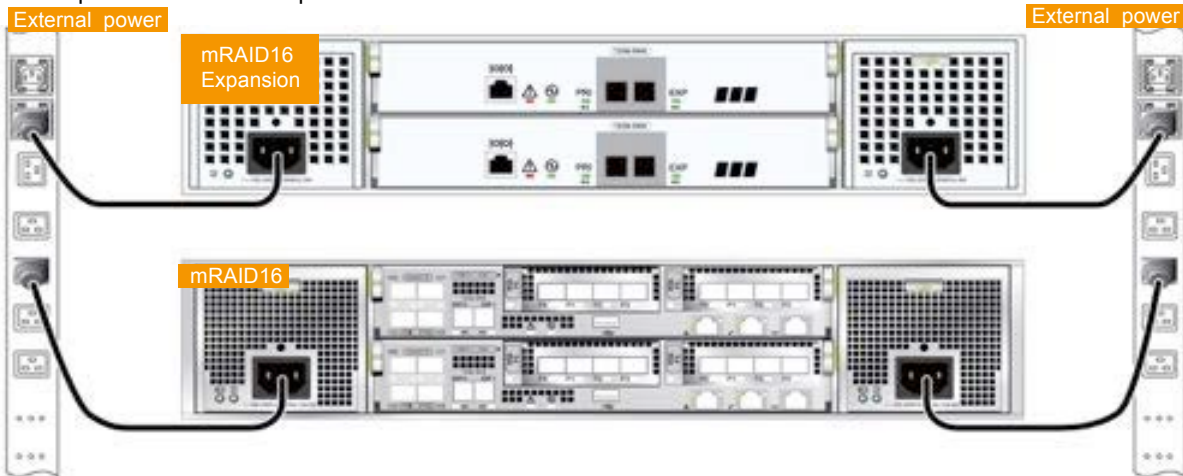

## 4 Checking Hardware Installation

### 4a Checking system installation

Check Item	Normal	Abnormal
mRAID16	<ul style="list-style-type: none"> <li>The system sits stably on the guide rails without displacement.</li> <li>Screws are properly secured.</li> </ul>	<ul style="list-style-type: none"> <li>The system slants or cannot be detected.</li> <li>Screws are loose or have fallen off.</li> </ul>
mRAID 16 Expansion		

### 4b Checking cable connections

Check Item	Normal	Abnormal
Ground cable, optical fiber cable, mini SAS HD electrical cable/optical cable, network cable, and serial cable	The cable is fully inserted and secured.	The cable is loose or disconnected.
AC power cable	<ul style="list-style-type: none"> <li>The AC power cables for each mRAID16 or mRAID16 Expansion are connected to two separate power supplies for redundancy.</li> <li>The AC power cables are secured with plastic buckles.</li> </ul>	<ul style="list-style-type: none"> <li>The AC power cables for each mRAID16 or expansion are connected to the same power supply.</li> <li>The AC power cables are not secured with plastic buckles.</li> </ul>

## 5 Powering On the mRAID16 and mRAID16 Expansion

### ⚠ NOTICE

- To avoid electric shocks, do not wear an ESD wrist strap when the mRAID16 is powering on.
- Do not adjust mini SAS HD electrical cable/optical cable connections between mRAID16 and mRAID16 Expansion after power-on.

### 📖 NOTE

The power-on process requires 5-15 minutes. Then the mRAID16 Expansions start power-on automatically.

- Follow the correct power-on sequence: Turn on the external power supplies (mRAID16 Expansions first and then mRAID16s). — Press the power buttons on the mRAID16s. — Turn on the FC switch. — Turn on the application servers.
- Follow the correct power-off sequence: Stop host services. — Press and hold down the power buttons on the mRAID16s until it is completely powered off (five seconds). — Disconnect the mRAID16s and the mRAID16 Expansions from their power supplies.

### 5a Switching on external power supplies

Turn on external power supplies in the following sequence:

mRAID16 Expansions → mRAID16 → FC switches (for a SAN) → application servers.

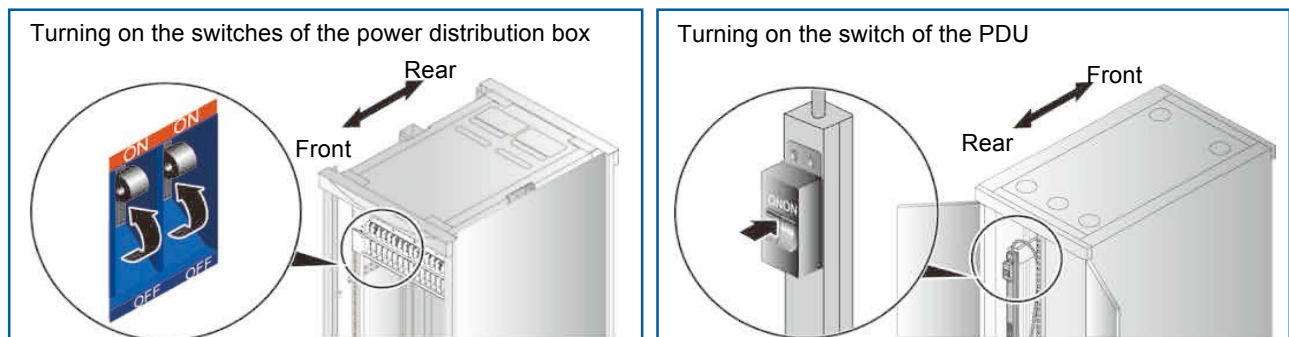

## 5b Pressing the power button on mRAID16



## 5c Checking status indicators on the mRAID16 and expansions



### NOTICE

After you have powered on a mRAID16 expansion or the mRAID16, check that all disks are working correctly (no alarm/location indicator is steady red).



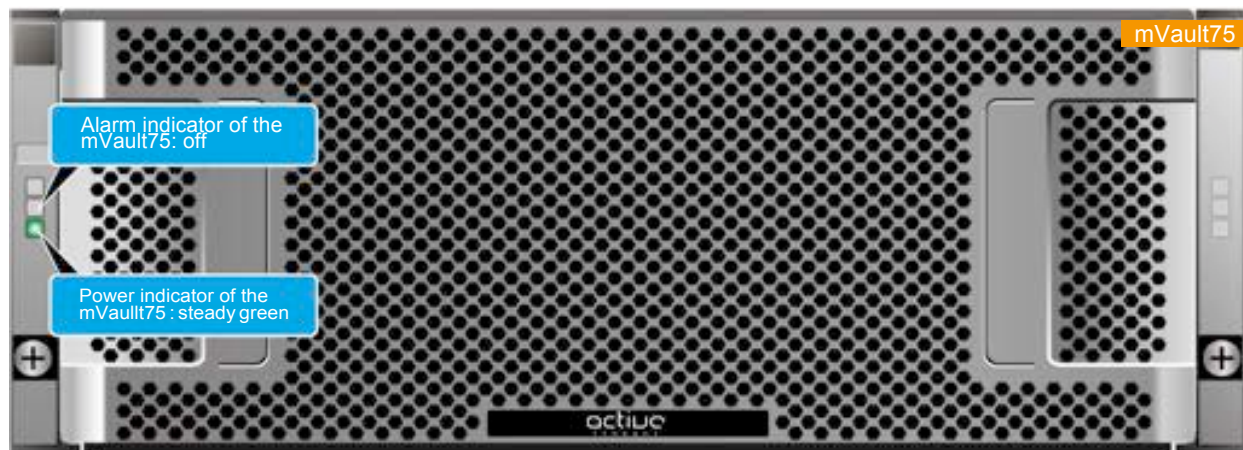

## 6 Initializing the mRAID16

After you have powered on the mRAID16, complete the following initialization steps:

1. Log in to the ActiveManager on the maintenance terminal using the IP address of the management network port.
2. Follow the **Settings > Initial Configuration** wizard to change the basic information, configure the system time, disk domain, alarm notification and import license files.

### NOTE

- The default user name and password of the mRAID16 are **admin** and **Active@active** respectively.
- The command to change password is **change user password**.

## 7 Configuring the mRAID16

For system configuration, please download the mRAID16 Quick Configuration Guide for SAN or NAS from the "Documents" section of our web site <http://active-storage.com>.

active™  
S T O R A G E

[www.activestorage.com](http://www.activestorage.com)

Copyright © Active Storage, LLC. 2017 – All Rights Reserved.  
All trademarks, tradenames, and copyrights are property of their respective holders.